



# CEMATE 5043

---

## FOR A NEW WORLD

JAC Motors since 1964  
Better Products Better World



# POWER PERFORMANCE

THE THREE CORE COMPONENTS, ENGINE, TRANSMISSION AND AXLES ARE INCORPORATION WITH INTERNATIONAL AND DOMESTIC BRANDS SO THAT THEIR RELIABLE QUALITY AND OPTIMIZE THE MATCHING ESTABLISH THE MOST ECONOMICAL, EFFICIENT AND HIGH END PRODUCT PLATFORM FOR DIFFERENT APPLICATIONS.



EMISSION LEVELS: EURO V

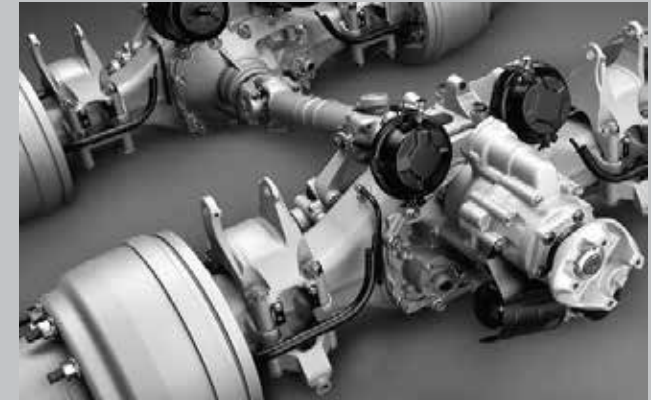
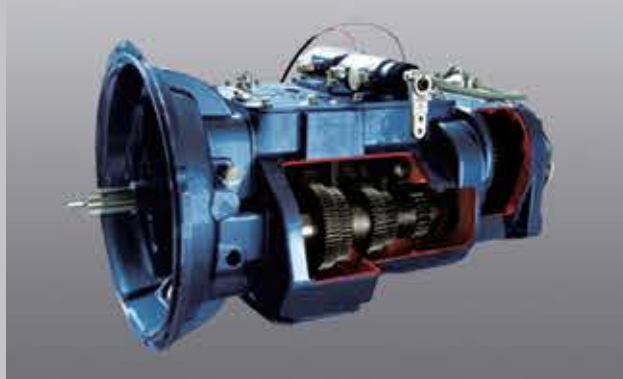

HORSE POWER: 430HP

# SAFETY

THE CAB OF REINFORCED SHEET METAL MATERIAL AND MULTIPLE SAFETY DEVICES IMPRESSIVELY IMPROVE THE DRIVING SAFETY.



## ECE SAFETY STANDARDS

Body shell is designed in accordance with the ECE European safety standards; 1.5mm-general thickness of cabin shell 3mm-thickness of collision area



## CRASH TEST OF CAB

complying with the ECE R29 protection terms; providing all-round protection



## REAR AXLE STABILIZER

enhancing driving stability in hilly area or road with lots of ups and downs Body shell is designed in accordance with the ECE European safety standards; 1.5mm-general thickness of cabin shell 3mm-thickness of collision area

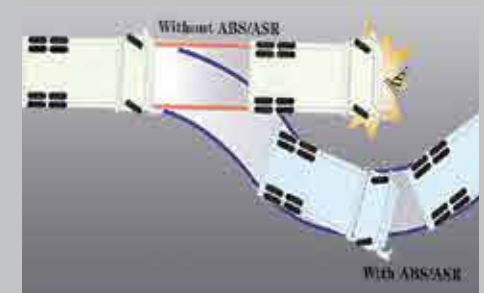

## ABS SYSTEM

High-level safety with ABS, ASR; Dual circuit air brake and all-around safety sensors

# LOADING CAPABILITY



RELIABLE MIXING COMPONENTS SUPPLIED BY PMP, ZF, REXROTH



OPTIMIZED DISCHARGE PORT



HIGH-STRENGTH STEEL, OPTIMIZED FRAME STRUCTURE; Seamlessly matched mainframe and sub-frame; stronger loading capacity and higher reliability



KEINTORCED FRAME 322\*100\*(8+10)



ADVANCED DESIGN  
Low center of gravity to improve abrasive resistance high strength steel to improve abrasive resistance



REINFORCED SUSPENSION  
Reinforced leaf spring suspension more stiffness and robustness with four U-bolt



TIRE multiple reliable brands; all-round types

# COMFORTABLE ENVIRONMENT

---

## SPACIOUS CAB

A spacious working place for driver; a relaxing atmosphere

## DASHBOARD

New fashion style; ergonomic, user-friendly and well-reaching feature; minimum distraction, car ambience; less driving fatigue

## CAB SPIRAL SPRING SUSPENSION

Vibration reduced, driver health protection, longer driving hours



# SPECIFICATIONS

---

- MODEL: CEMATE A5 5043
- CAB TYPE: A5W
- VEHICLE DIMENSIONS (L×W×H): 1055025004000 mm
- CHASSIS DIMENSIONS (L×W×H): 8995×2567×3280 mm
- WHEELBASE: 1900+3000+1450 mm
- FRAME SECTION SIZE: 322×80×(10+8) mm
- MIXER TANK VOLUME: 12 m<sup>3</sup>
- BARREL WALL THICKNESS: 5mm
- BARREL WALL MATERIAL: T520JJ
- MIXING BLADES THICKNESS: 3.5mm
- MIXING BLADES MATERIAL: BWP300
- LOADING SPEED: ≥ 2.7 m<sup>3</sup>/min
- DISCHARGING SPEED: ≥ 0.65 m<sup>3</sup>/min
- REST RATE: ≤1%
- MIXER SPEED: 0-16 rpm
- MIXER TANK ANGLE: 10°
- WATER TANK VOLUME: 1000L
- SPEED REDUCTION GEAR: PMP 7.1Y, ITALY BRAND
- PUMP: PMP 90, ITALY BRAND
- MANUFACTURER: CIMC
- GVW: 50000 kg
- CAB ACCESSORIES: Door lock (Remote-control), Cab flip (Electric-controlled), Window glass (Electric-controlled), Driver seat (Air-seat), Co-driver seat (Mechanical seat), Air Condition, Warm air, Air filter (Enhanced air-filter for sand/dusty working condition), Engine guard
- ENGINE MODEL: WP12.430E50
- EMISSION: Euro V
- RATED OUTPUT POWER: 430 hp/1900 rpm
- MAX TORQUE: 2060 N·m/rpm (1000-1400 rpm)
- DISPLACEMENT: 11596 cc
- PTO: 1000 n.m
- TRANSMISSION MODEL: 12JSDX240T+QH70
- REAR AXLE RATIO: 13.15/1.00
- FRONT AXLE MAXIMUM CAPACITY: 2 x 9000kg
- REAR AXLE MAXIMUM CAPACITY: 2 x 16000kg
- STEERING TYPE: Power steering with BOSCH Steering gear
- FUEL TANK MATERIAL: Aluminium alloy
- FUEL TANK VOLUME: 400 L
- TIRE SIZE: 315/80 R22.5
- SUSPENSION: Parabolic leaf spring 9/9/12
- ACOUSTICAL EQUIPMENT: MP3, Reverse alarm
- SAFETY CONFIGURATION: ABS, Engine brake, Exhaust auxiliary brake